

DIMENSION/TOLERANCE	
A O.A.L.	
B L.O.C.	
C DIAMETER	
D SHANK DIA.	
E RAD./CHMF.	
F NECK DIA.	
G NECK LGTH.	
H MIN. CUT DIA.	
J ° CUTTER	

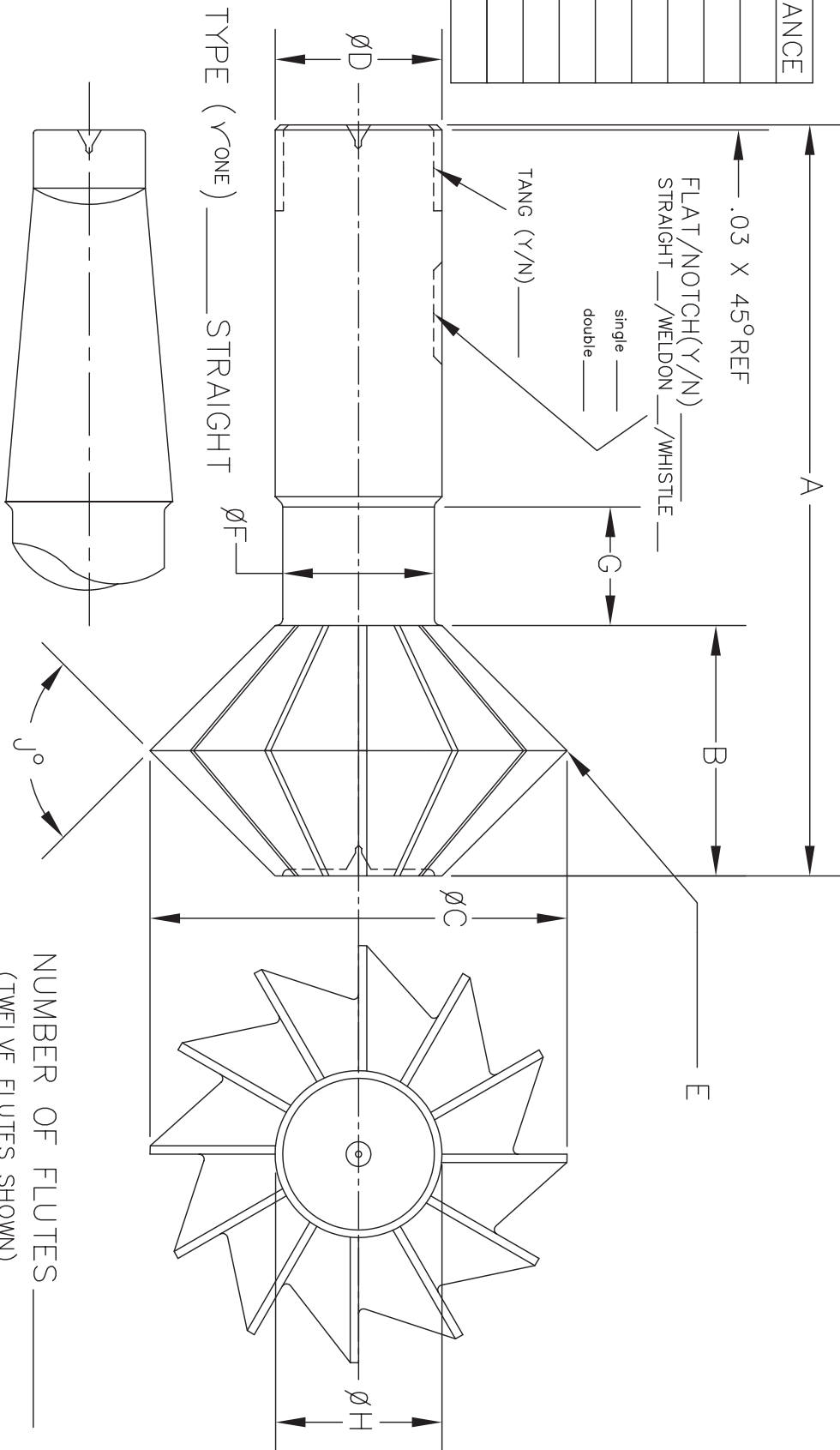

TYPE (✓ONE) \_\_\_\_\_ STRAIGHT  
 TYPE (✓ONE) \_\_\_\_\_ TAPER SHANK  
 MORSE \_\_\_\_\_ B&S \_\_\_\_\_ JARNO \_\_\_\_\_

NUMBER OF FLUTES \_\_\_\_\_  
 (TWELVE FLUTES SHOWN)  
 END CUT (Y/N) \_\_\_\_\_

TOOL MAT'L. (✓ONE)

- \_\_\_\_\_ H.S.S.
- \_\_\_\_\_ COBALT
- \_\_\_\_\_ CARBIDE TIPPED
- \_\_\_\_\_ SOLID CARBIDE
- \_\_\_\_\_ CARBIDE/HEADED

COATING \_\_\_\_\_

COMPANY		<b>SPECIAL DOUBLE ANGLE CUTTER</b>	<b>CONFIDENTIAL</b>
NAME			
DATE			
SIGNATURE			
TITLE		ALL DIMENSION ARE IN INCHES UNLESS OTHERWISE SPECIFIED TOLERANCE IS: X' ±1.00' .XX ±.010 .XXX ±.005 .XXXX ±.0005 BREAK ALL SHARP EDGES	
		AMERICAN TOOL SERVICE, INC. 7007 TRAFALGAR STREET FORT WAYNE, IN 46803 PH.260-493-1230 FX.260-493-6702	SCALE <b>NOT TO SCALE</b> DRAWING NO.